

0 601 1A2 1F1 – GSB 20-2 RE

Material number	0 601 1A2 1F1
EAN	3165140644624
Auxiliary handle	✓
Chuck key	✓
Depth gauge	✓



Technical data

Technical data

Rated input power	800 W
No-load speed, 1st gear	0 – 1,100 rpm
No-load speed, 2nd gear	3,000 rpm
Weight	2.5 kg
Rated speed	740 rpm
Rated torque	5.2 / 2.0 Nm
Chuck capacity, min./max.	1.5 – 13 mm
Tool dimensions (width)	85 mm
Tool dimensions (length)	346 mm
Tool dimensions (height)	220 mm
Impact rate at no-load speed	0 – 48,000 bpm
Drill chuck, version	Keyed chuck

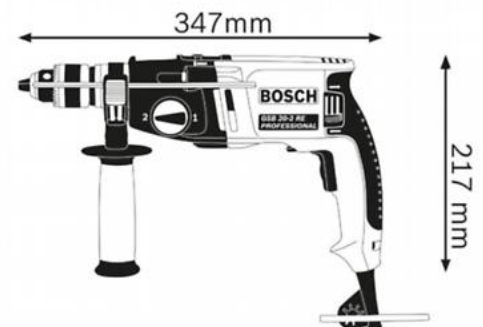

Drilling range

Drilling diameter in concrete	16 / 20 mm
Drilling diameter in wood	25 / 40 mm
Drilling diameter in steel	8 / 13 mm
Drilling diameter in masonry	22 mm

Noise/vibration information

Noise level	The A-rated noise level of the power tool is typically as follows: Sound pressure level dB(A); Sound power level dB(A). Uncertainty K= dB.
-------------	--

Sales information

Positioning

- Powerful, dual-speed impact drill with superior durability and performance

User benefit

- Increased robustness with pot stacked metal gear housing design
- Powerful 800 W motor for enhanced performance and durability
- 2 gear functionality for dual speed coupled with dual mode impact shifter for increased versatility

